

Model: NU145

VENTILATION PERFORMANCE

ENERGY PERFORMANCE

EXT. STATIC PRESSURE in wg (Pa)	NET SUPPLY AIR FLOW cfm (l/s)	GROSS AIR FLOW SUPPLY cfm (l/s)	GROSS AIR FLOW EXHAUST cfm (l/s)	SUPPLY TEMP. °F (°C)	NET AIR FLOW cfm (l/s)	POWER CONSUMED Watts	SENSIBLE RECOVERY EFFICIENCY	APPARENT SENSIBLE EFFECTIVENESS
0.1 (25)	143 (67)	144 (68)	174 (82)	+32 (0)	64 (30)	50	71%	80%
0.2 (50)	124 (58)	125 (59)	150 (71)	+32 (0)	96 (45)	80	64%	73%
0.3 (75)	109 (51)	110 (52)	135 (64)	+32 (0)	116 (55)	90	63%	70%
0.4 (100)	100 (47)	101 (48)	122 (58)					
0.5 (125)	92 (43)	93 (44)	104 (49)	13 (-25)	60 (28)	69	64%	82%
0.6 (150)	78 (37)	79 (37)	93 (44)					
0.7 (175)	63 (30)	64 (30)	86 (41)					
0.8 (200)	46 (22)	47 (22)	72 (34)					



CABINET/CORE: Collar size: 6-inch (152 mm); 5th Port: 5-inch (127 mm). The case is constructed of 0.032 painted aluminum with a white enamel finish. The cabinet is fully insulated with 1-inch polyurethane. The unit is equipped with a polypropylene cross-flow heat exchange core. Shipping weight: 30 lb (13.6 kg).

CERTIFICATION: cCSAus, HVI. Meets CSA F326, Novoclimat and ASHRAE 62.2 requirements.

ELECTRICAL: 120V/1/60 Hz. 100W, 0.9A

BLOWERS: Two backward curve impellers using PSC motors and permanently sealed bearings.

REVERSIBLE:
internal components
can be accessed
front or back.

ADDITIONAL FEATURES:

- Furnace interlock options: commands furnace blower when HRV is on or only on high speed.
- Intelligent Defrost: duration and interval adjust to outdoor conditions below -5° C (23° F).
- **In defrost and recirculation modes, this unit will not induce indoor negative pressure nor recycle exhaust air; rather, it will redistribute ambient room air.**
- Balancing: differential pressure ports on doors allow air measurements without flow grid in ductwork. Independent speed adjustment of either supply or exhaust motor in BOTH high and low speed.
- 24 V circuit protection with self resetting fuse.
- Drain, hanger kit featuring buckle-fitted adjustable poly straps, polyester air filters included.
- 12 VDC or 24 V remote control options with the following Nu-Air controls:

ES Series (12 VDC): Unlimited numbers. Series or parallel.	WINDSOR Series (24 V)
ES-M1: Off/ Stby/ Lo/ Hi ES-M2: Off/ Stby/ Lo/ 20 Lo—40 Stby ES-M3: Off/ Stby/ Lo/ 20 Lo—40 Recirculation ES-M4: Off/ Stby/ Lo/ Recirculation ES-T1: 20-40-60-minute timer ES Lumina (NAV-561): Low speed, high speed, intermittent, recirculation, 20/40 standby/lo, 20/40 recirculation, 20-40-60-minute timer, filter alert	DSTAT-1: Humidity control Win-1: Humidity control/ OFF/ STBY/ Continuous/ Intermittent/ Full-time high speed *WIN-20: 20-minute timer (up to 6), *WIN-20 Gang: for multi-switch gang box Also: Any 24 V, two-wire switch. *Compatible with 12 VDC options.

Defrost: When outdoor temperature falls to -5° C (23° F), an automatic timed defrost cycle is initiated. The fresh air motor will go to high speed and the exhaust air motor will turn off. A damper will shut off the cold supply port, directing ambient air through the core for defrosting. The unit will resume normal operation for a fixed duration, then the processor will read outdoor temperature and initiate defrost as necessary. Defrost varies with outdoor temperature.

Warranty: There is a 3-year warranty on all internal components. The heat recovery core has a lifetime warranty.

Notes:

This product earned the ENERGY STAR® by meeting strict energy efficiency guidelines set by Natural Resources Canada and the US EPA. It meets ENERGY STAR requirements only when used in Canada.

Model: ES150

Notes:

1. Outside air
2. Supply air
3. Return air
4. Exhaust air
5. 5" Recirculation port
6. Backward curved impellers
7. Defrost damper
8. Cross flow core
9. Remote connections
10. Washable filters (2)
11. Hanger nutserts (4)
12. 1/2" Drains (2)
13. 5" Collar
14. 6" Collars (4)

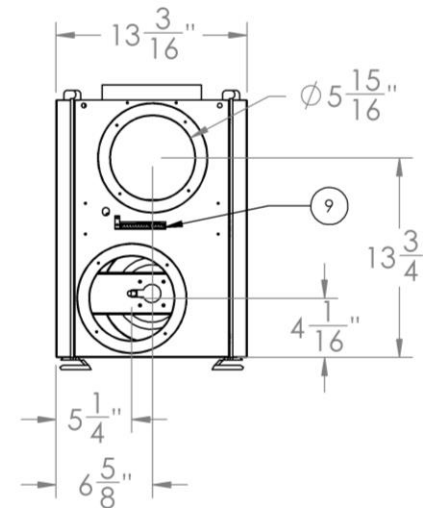
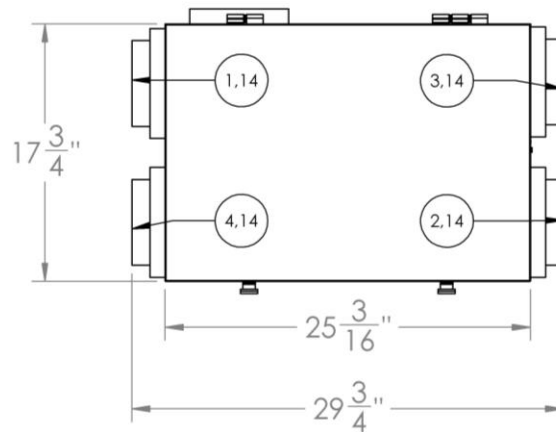
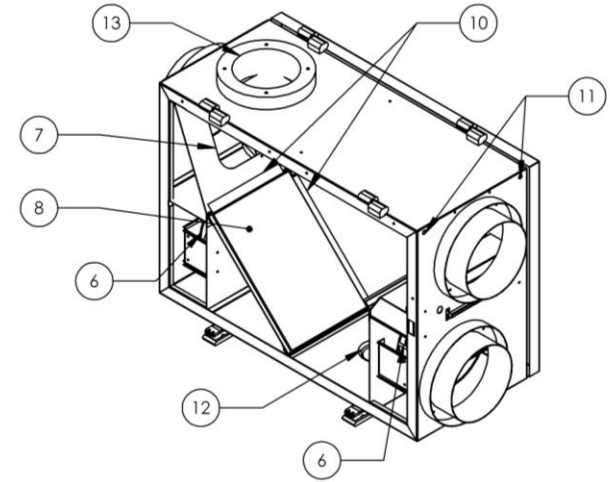
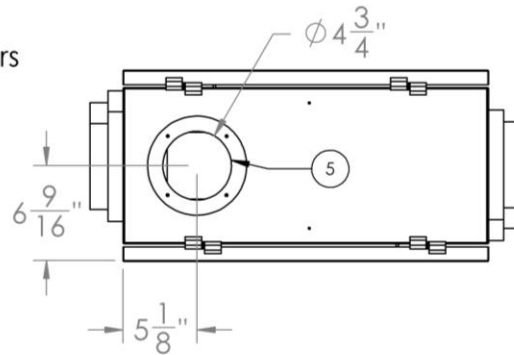

Unit is Reversible
 2 Doors are removable
 if required for access
 to core and routine
 maintenance